

Water Meter Contactors



WFM Series

WFM Series water meters have earned a reputation for design simplicity, wide range of applications and accuracy in low-quality water. The impeller is centered in a ring of jets, with inlet jets on one level and outlet jets on another. A gear train drives the register totalizer dials.



For pulse output, one of the pointers is replaced by a magnet, which is detected by an encapsulated sensor attached to the outside of the lens. Pulse rate is determined by the dial on which the magnet is placed and by the number of sensors (single or double). Changing the pulse rate requires no special tools and can be done in the field.

The WFM Series uses the widely recognized multi-jet principle, which has been accepted as an international standard for many years. These meters are available with either a two-wire reed switch, or a solid state, three-wire Hall effect sensor.

The Hall effect sensor provides long lasting service and requires power. The reed switch provides a dry contact closure and does not require power. The WFM meters are typically used in cold water applications with cooling tower or boiler conductivity controllers and metering pumps for chemical feed. They do not have NSF Standard 61 certification for drinking water applications.

Summary of Key Benefits

- Simple and dependable multi-jet design.
- Available in 3/4", 1", 1 1/2" and 2" NPT sizes for flow rates from 0.22 to 132 GPM.
- A wide range of pulse rates for a variety of applications.
- Reed switch or Hall effect sensor options.

* Not approved for drinking water.

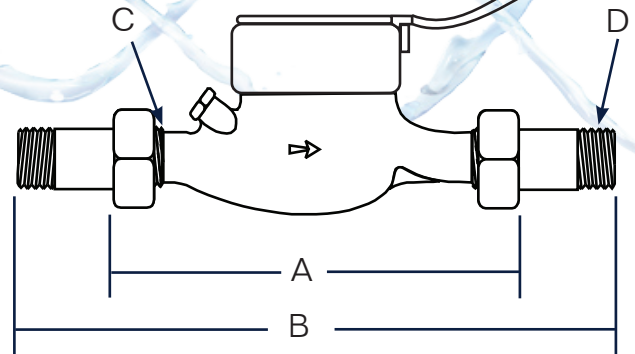

DIMENSIONS	3/4"	1"	1 1/2"	2"
A (Body)	7 1/2"	10 1/4"	11 3/4"	
B (Body with couplings)	12 5/8"	15 5/8"	17 5/8"	
C (BSP thread)	1"	1 1/4"	2"	2 1/2"
D (NPT thread)	3/4"	1"	1 1/2"	2"
Shipping Weight (lbs)	7	9	14	18

PULSE RATES AVAILABLE

3/4"		1"		1 1/2"		2"	
Pulses/Gal	Gallon/Pulse	Pulses/Gal	Gallon/Pulse	Pulses/Gal	Gallon/Pulse	Pulses/Gal	Gallon/Pulse
*20	1	*2	1	*2	1	*2	1
10	*5		*5		*5		
*2	10		10		10		
	*50		*50		*50		
	100	100	100				

*These pulse rates available in WFMxx1 (reed switch) only

WALCHEM

IWAKI America Inc.

Ordering Information

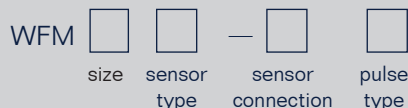

SIZE

07 = ¾"
10 = 1"
15 = 1½"
20 = 2"

SENSOR TYPE

0 = No sensor, Totalize only
1 = Reed switch, 2 wire
2 = Hall effect, 3 wire

SENSOR CONNECTION

0 = Wire only, no connector
3 = Includes E90495 connector for EW pump

PULSE TYPE

P = Pulses per Gallon
G = Gallons per Pulse

PULSE RATE

See Pulse Rate Chart

SPECIFICATIONS

Power

Sensor	Reed switch	Hall effect
Max.Current	20 mA	20 mA
Max.voltage	24 VDC or VAC	24 VDC
Power	None	min 6mA @ 12VDC

Pressure Maximum 150 psi operating

Temperature Maximum 105°F (40°C)

Cable Length 12 ft. standard, 2000 ft. max.

Materials of Construction

Body	Cast Bronze
Internals	Engineered Thermoplastic
Magnet	Alnico

Flow Rates (GPM)

Size	Minimum	Maximum
¾"	0.22 GPM	22 GPM
1"	0.44 GPM	52 GPM
1½"	0.88 GPM	88 GPM
2"	1.98 GPM	132 GPM

Accuracy ± 1½ % of reading



WebmasterONE®

WebMasterONE® is the most powerful online cooling tower/boiler controllers in the water treatment industry. WebMasterONE® couples a multi-I/O platform with Walchem's analytical sensors and extensive communications technologies. The result is the ability to remotely monitor and control your process from any computer, anywhere in the world, with just a standard web browser.



Metering Pumps

Iwaki metering pumps are designed for a broad range of applications, and are manufactured to the highest quality standards that exceed even the toughest customer expectations. Our commitment to new product development and innovation has resulted in many industry firsts, including EK - the world's first IP67 waterproof solenoid metering pump.



WIND WebMaster Industrial Water Controllers

Walchem's WebMaster® Industrial (WIND) Controller sets a new standard for Industrial Water Treatment Controllers. WIND has a flexible multi-I/O platform, a wide range of analytical sensor measurement capabilities, and an extensive assortment of integrated communications and data handling features.



WebAlert Remote Monitor

Walchem's WebAlert is the first stand alone remote monitoring device that can web enable your installed equipment without having to replace or upgrade it.

ABOUT US

Walchem integrates its advanced sensing, instrumentation, fluid pumping and communications technologies to deliver reliable and innovative solutions to the global water treatment market. Our in-house engineering is driven by quality, technology and innovation. For more information on the entire Walchem product line, visit: www.walchem.com.