

PLAN VIEW

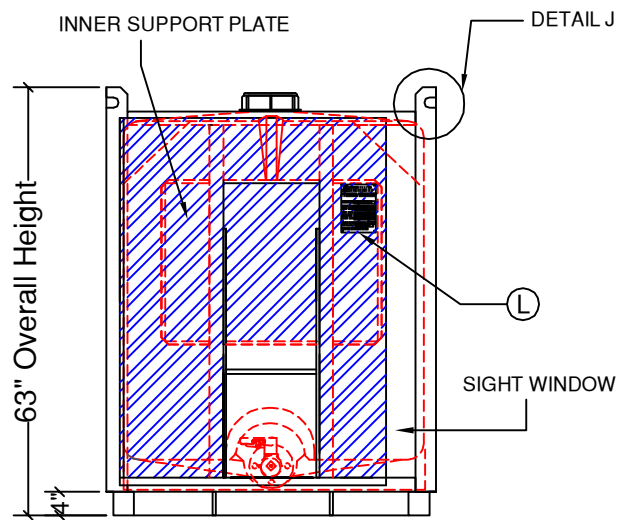

FRONT VIEW

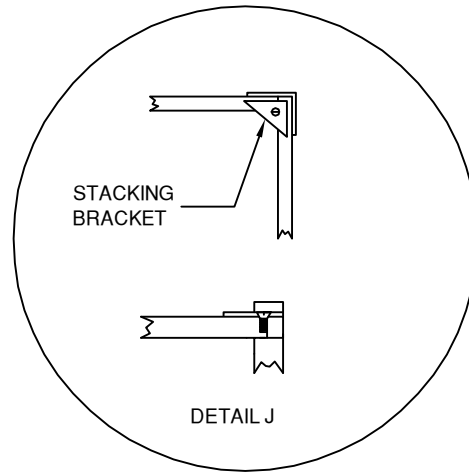
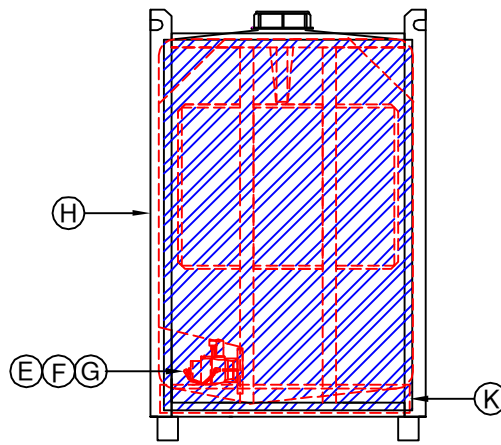

SIDE VIEW

MATERIALS LIST

ITEM	SIZE	DESCRIPTION	NOTES
A		270 IG (1230 L) POLYETHYLENE BOTTLE	
B	6"	ORANGE HDPE THREADED LID WITH TIE-DOWN	
C		LID GASKET	EPDM OR VITON
D		VENT - VACUUM & PRESSURE RELIEF (OPTIONAL)	IN LID
E	2"	FLANGE GASKET	EPDM OR VITON
F	2"	BALL VALVE; POLYPROPYLENE OR 316-SS	FNPT OR CAMLOC
G		VALVE MOUNTING HARDWARE KIT	
H		FULLY ENCLOSED STEEL FRAME AND VALVE PROTECTION GATE	
J		FRAME CORNER STACKING BRACKET W/ SCREW	4 PCS REQUIRED
K		BLACK POLY FRAME PILLOW	
L		ALUMINUM U.N. FRAME TAG	

TECHNICAL DATA:

- CAPACITY: 270 IMP GAL, 1230L
- WEIGHT: 740 LBS, 336 KG (APPROX) EMPTY
- PRIMARY MARKINGS: U.N. 31HA1/Y/

REV	DATE	DESCRIPTION	BY	APPD	REVD

REVISIONS

CUSTOMER

TITLE

ACO JOB NO:

PURCHASE ORDER NO:

PURCHASER'S EQUIP. NO:

THIS DRAWING IS THE PROPERTY OF ACO CONTAINER SYSTEMS LTD. AND SHALL NOT BE COPIED OR TRANSFERRED WITHOUT THE WRITTEN CONSENT OF ACO CONTAINER SYSTEMS LTD.

ENGINEERS SEAL

**ACO CONTAINER SYSTEMS LTD.**

PICKERING - ONTARIO - CANADA

ACO CONTAINER SYSTEMS LTD.  
794 MCKAY RD.  
PICKERING, ONTARIO, CANADA  
L1W 2Y4  
TEL. 905-683-8222  
FAX 905-683-2969

DESIGNED	S.A.
DRAWN	J.M.
CHECKED	
APPROVED	
SCALE	N.T.S.
DATE	04-16-07

DWG No

**PTC-270-FE**

REV

**0**